

Please check the examination details below before entering your candidate information

Candidate surname

Other names

**Pearson Edexcel  
Functional Skills**

Centre Number

Candidate Number

**Practice Set 2**

Time: 25 minutes

Paper Reference **PRACL1/N02**

**Mathematics**

**Level 1**

**Section A (Non – Calculator)**



**You must have:**

Pen, HB pencil, eraser, ruler graduated in cm and mm, protractor, pair of compasses. Tracing paper may be used.

Total Marks

**My signature confirms that I will not discuss the content of the test with anyone.**

Signature: \_\_\_\_\_

### Instructions

- Use **black** ink or ball-point pen.
- **Fill in the boxes** at the top of this page with your name, centre number and candidate number.
- Sign the declaration.
- Answer **all** questions.
- Write your final answers in the boxes provided.
- Answer the questions in the spaces provided – *there may be more space than you need.*
- You **must** show clearly how you get your answers in the spaces provided. Marks will be awarded for your working out.
- Check your working and answers at each stage.
- Diagrams are **not** accurately drawn, unless otherwise indicated.
- **Calculators may not be used.**
- Take the value of  $\pi$  to be 3.14

### Information

- The total mark for this section is 14.
- The marks for **each** question are shown in brackets.  
– *use this as a guide as to how much time to spend on each question.*
- This sign  shows where marks will be awarded for showing your checks.

### Advice

- Read each question carefully before you start to answer it.
- Check your answers if you have time at the end.

Turn over ►

S68212A

©2020 Pearson Education Ltd.

1/1/1



  
**Pearson**

**SECTION A**

**Answer ALL questions. Write your answers in the spaces provided.**

- 1** Joe works for a charity.  
Each year the charity gives money to different projects.

The charity has a total of eight thousand nine hundred and sixty-eight pounds to give to the projects this year.

Joe needs to share the total money equally between 8 projects.

Work out how much money each project will receive.

(3)

£

**(Total for Question 1 is 3 marks)**

DO NOT WRITE IN THIS AREA

DO NOT WRITE IN THIS AREA

DO NOT WRITE IN THIS AREA

DO NOT WRITE IN THIS AREA

DO NOT WRITE IN THIS AREA

DO NOT WRITE IN THIS AREA



DO NOT WRITE IN THIS AREA

DO NOT WRITE IN THIS AREA

DO NOT WRITE IN THIS AREA

DO NOT WRITE IN THIS AREA

DO NOT WRITE IN THIS AREA

DO NOT WRITE IN THIS AREA

2 Alex is going to cook a chicken.

He uses this rule to work out the total time needed to cook the chicken.

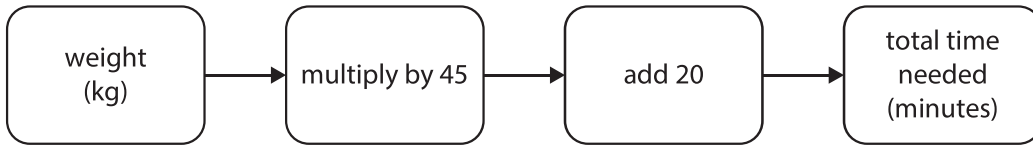

The weight of the chicken is 3 kg.

Use the rule to find the total time needed to cook the chicken.  
Give your answer in minutes.

(3)

minutes

(Total for Question 2 is 3 marks)



3 Kiara needs a container to put in her freezer.

She sees this container.

The container is in the shape of a cuboid.

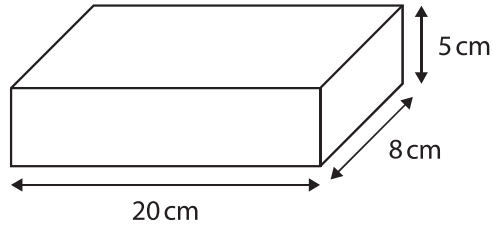

Kiara knows  $1000 \text{ cm}^3 = 1 \text{ litre}$ .

She thinks the container holds more than  $\frac{3}{4}$  litre.

Is Kiara correct?  
You **must** show your working.

(4)

(Total for Question 3 is 4 marks)

DO NOT WRITE IN THIS AREA

DO NOT WRITE IN THIS AREA

DO NOT WRITE IN THIS AREA

DO NOT WRITE IN THIS AREA

DO NOT WRITE IN THIS AREA

DO NOT WRITE IN THIS AREA



4 Zane needs to travel from Sheffield to London on Saturday.

The table shows the cost for the different types of transport.

type of transport	cost (£)
train first class	47.25
train standard class	34.00
bus	6.30
car	26.52

(a) Calculate the range of these costs.

(2)

£

Zane buys a standard class train ticket.  
He uses a 15% discount voucher.

(b) How much money does he save with this voucher?

(2)

£

(Total for Question 4 is 4 marks)

TOTAL FOR SECTION A IS 14 MARKS



DO NOT WRITE IN THIS AREA

DO NOT WRITE IN THIS AREA

DO NOT WRITE IN THIS AREA

DO NOT WRITE IN THIS AREA

DO NOT WRITE IN THIS AREA

DO NOT WRITE IN THIS AREA

BLANK PAGE



DO NOT WRITE IN THIS AREA

DO NOT WRITE IN THIS AREA

DO NOT WRITE IN THIS AREA

DO NOT WRITE IN THIS AREA

DO NOT WRITE IN THIS AREA

DO NOT WRITE IN THIS AREA

BLANK PAGE



S 6 8 2 1 2 A 0 7 0 8

DO NOT WRITE IN THIS AREA

DO NOT WRITE IN THIS AREA

DO NOT WRITE IN THIS AREA

BLANK PAGE





Please check the examination details below before entering your candidate information

Candidate surname

Other names

**Pearson Edexcel  
Functional Skills**

Centre Number

Candidate Number

**Practice Set 2**

Time: 1 hour 30 minutes

Paper Reference **PRACL1/C02**

**Mathematics**

**Level 1**

**Section B (Calculator)**



**You must have:**

Pen, calculator, HB pencil, eraser, ruler graduated in cm and mm, protractor, pair of compasses. Tracing paper may be used.

Total Marks

**My signature confirms that I will not discuss the content of the test with anyone.**

Signature: \_\_\_\_\_

**Instructions**

- Use **black** ink or ball-point pen.
- **Fill in the boxes** at the top of this page with your name, centre number and candidate number.
- Sign the declaration.
- Answer **all** questions.
- Write your final answers in the boxes provided.
- Answer the questions in the spaces provided – *there may be more space than you need.*
- You **must** show clearly how you get your answers in the spaces provided. Marks will be awarded for your working out.
- Check your working and answers at each stage.
- Diagrams are **not** accurately drawn, unless otherwise indicated.
- **Calculators may be used.**
- If your calculator does not have a  $\pi$  button take the value of  $\pi$  to be 3.14

**Information**

- The total mark for this section is 42.
- The total mark for this paper is 56.
- The marks for **each** question are shown in brackets.  
– *use this as a guide as to how much time to spend on each question.*
- This sign  shows where marks will be awarded for showing your checks.

**Advice**

- Read each question carefully before you start to answer it.
- Check your answers if you have time at the end.

Turn over ►

S68213A

©2020 Pearson Education Ltd.

1/1/1/1



  
**Pearson**

**SECTION B**

**Answer ALL questions. Write your answers in the spaces provided.**

- 1** Jasper decorates flower pots to sell in his shop.  
He knows that it takes 12 minutes to decorate a flower pot.

Jasper works from 9.30 am until 12.50 pm on Tuesday.  
He takes 20 minutes for a coffee break at 10.30 am.

How many flower pots does Jasper decorate on Tuesday?

(3)

**(Total for Question 1 is 3 marks)**

DO NOT WRITE IN THIS AREA

DO NOT WRITE IN THIS AREA

DO NOT WRITE IN THIS AREA

DO NOT WRITE IN THIS AREA

DO NOT WRITE IN THIS AREA

DO NOT WRITE IN THIS AREA



DO NOT WRITE IN THIS AREA

DO NOT WRITE IN THIS AREA

DO NOT WRITE IN THIS AREA

DO NOT WRITE IN THIS AREA

DO NOT WRITE IN THIS AREA

DO NOT WRITE IN THIS AREA

2 Cruz is the editor of a magazine.

The magazine has 40 pages.

The magazine must have

- 20% of the pages for adverts
- $\frac{1}{4}$  of the pages for photos
- the remaining pages for articles.

Work out the number of pages for articles in the magazine.

(4)

pages

(Total for Question 2 is 4 marks)



3 Amy wants new skirting boards in her living room.

The skirting boards will

- go along the bottom of each wall
- not go across the doorway
- not go across the fireplace.

Amy has this sketch of her living room.

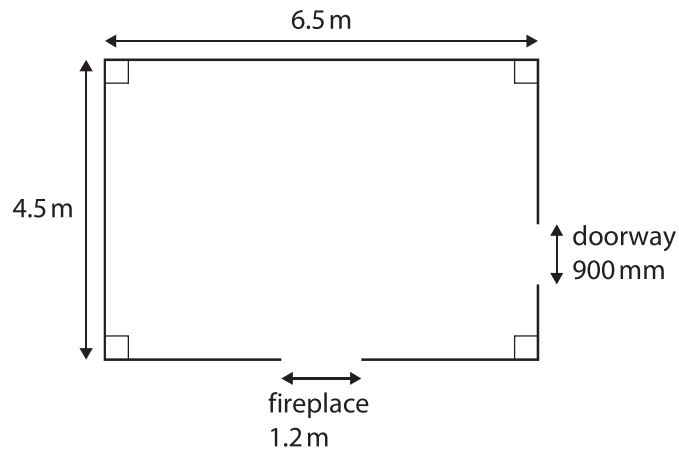

Skirting boards come in lengths of 2.4 m  
The lengths of skirting board can be cut and joined.

How many lengths of skirting board does Amy need?  
You **must** show your working.

(5)

DO NOT WRITE IN THIS AREA

DO NOT WRITE IN THIS AREA

DO NOT WRITE IN THIS AREA

DO NOT WRITE IN THIS AREA

DO NOT WRITE IN THIS AREA

DO NOT WRITE IN THIS AREA



DO NOT WRITE IN THIS AREA

DO NOT WRITE IN THIS AREA

DO NOT WRITE IN THIS AREA

DO NOT WRITE IN THIS AREA

DO NOT WRITE IN THIS AREA

DO NOT WRITE IN THIS AREA



**(Total for Question 3 is 5 marks)**



4 John is a milkman.

The table shows information about the types of milk John delivers each day.

type of milk	number	angle
skimmed	20	60°
semi skimmed	55	165°
whole	45	135°

Draw a pie chart to show this information  
Remember to label the chart.

(3)

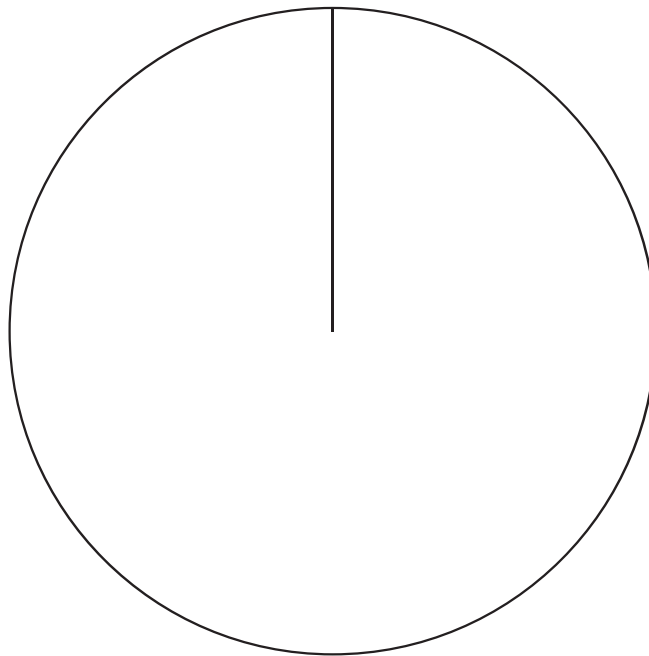

(Total for Question 4 is 3 marks)

DO NOT WRITE IN THIS AREA

DO NOT WRITE IN THIS AREA

DO NOT WRITE IN THIS AREA

DO NOT WRITE IN THIS AREA

DO NOT WRITE IN THIS AREA

DO NOT WRITE IN THIS AREA



DO NOT WRITE IN THIS AREA

DO NOT WRITE IN THIS AREA

DO NOT WRITE IN THIS AREA

DO NOT WRITE IN THIS AREA

DO NOT WRITE IN THIS AREA

DO NOT WRITE IN THIS AREA

5

(a) Draw a hexagon.

(1)

Here is a shape.

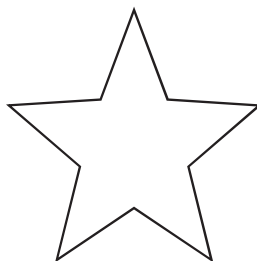

(b) How many lines of symmetry does this shape have?

(1)

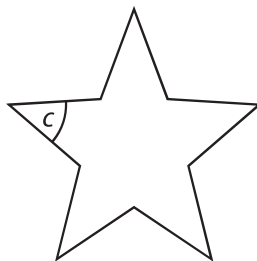

(c) Which of these words describes angle  $c$  in the shape above?

Tick [✓] the correct box below.

(1)

obtuse

acute

right

reflex

straight

(Total for Question 5 is 3 marks)



6 Martyn is a groundsman at a sports club.

He records the percentage of grass coverage in 12 places on a sports pitch.

Martyn lists the results.

grass coverage (%)			
55	32	64	45
49	18	83	74
27	91	40	62

Martyn starts to show this information in a grouped frequency table.

He will use five groups of equal size.

(a) Complete the grouped frequency table for Martyn.

(3)

grass coverage (%)	tally	frequency
1 to 20		1
	total	

DO NOT WRITE IN THIS AREA

DO NOT WRITE IN THIS AREA

DO NOT WRITE IN THIS AREA

DO NOT WRITE IN THIS AREA

DO NOT WRITE IN THIS AREA

DO NOT WRITE IN THIS AREA





DO NOT WRITE IN THIS AREA

DO NOT WRITE IN THIS AREA

DO NOT WRITE IN THIS AREA

DO NOT WRITE IN THIS AREA

DO NOT WRITE IN THIS AREA

DO NOT WRITE IN THIS AREA

Martyn clears all the rubbish left at the sports club.

He counts all the plastic drink bottles left each day for 60 days.

The table shows the results.

number of plastic bottles	frequency
0 – 9	2
10 – 19	12
20 – 29	15
30 – 39	23
40 – 49	8

Martyn wants to display this information in a chart.

(b) Draw a chart to show this information.

(3)

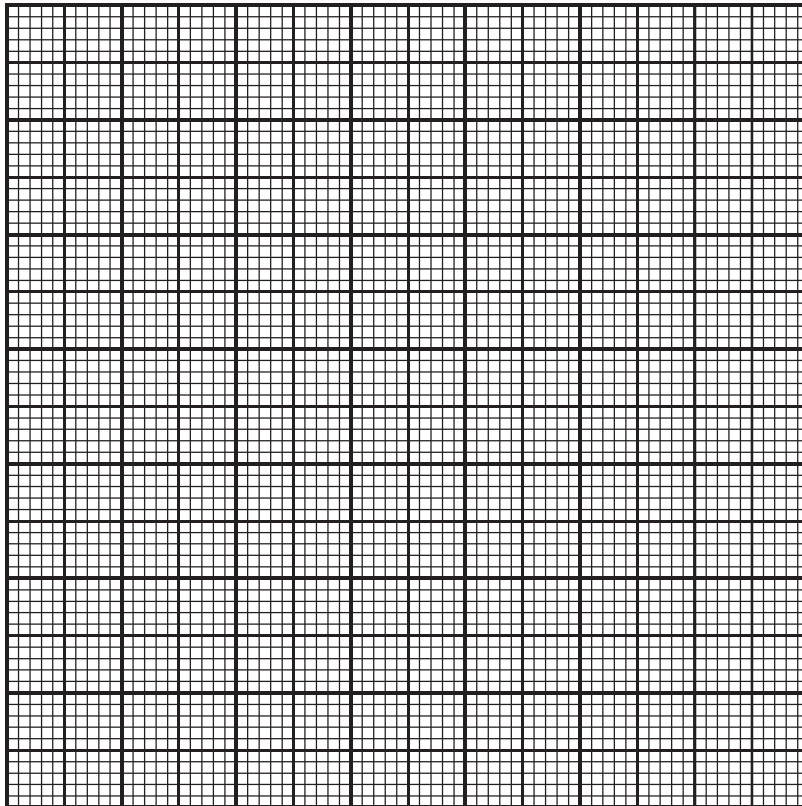

(Total for Question 6 is 6 marks)



- 7 Here is a prism.  
All corners on the prism are right angles.

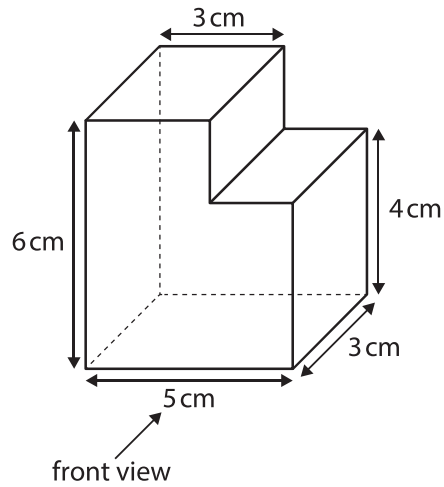

(a) How many faces are there on the prism?

(1)

The centimetre grid below shows four different views of the prism.

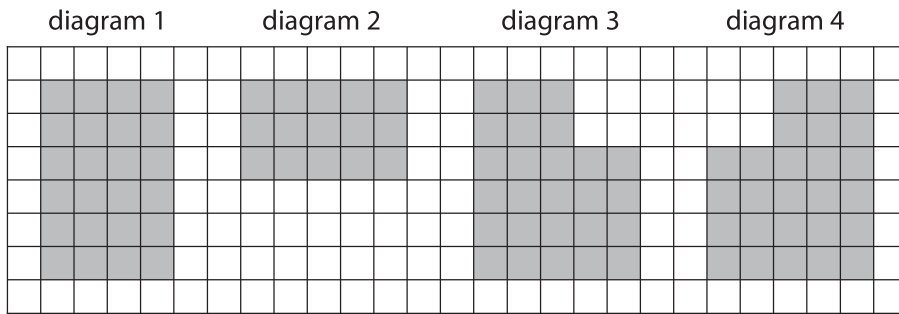

(b) Which diagram shows the plan view?

(1)

(c) Which diagram shows the back view?

(1)

(Total for Question 7 is 3 marks)

DO NOT WRITE IN THIS AREA

DO NOT WRITE IN THIS AREA

DO NOT WRITE IN THIS AREA

DO NOT WRITE IN THIS AREA

DO NOT WRITE IN THIS AREA

DO NOT WRITE IN THIS AREA



DO NOT WRITE IN THIS AREA

DO NOT WRITE IN THIS AREA

DO NOT WRITE IN THIS AREA

DO NOT WRITE IN THIS AREA

DO NOT WRITE IN THIS AREA

DO NOT WRITE IN THIS AREA

8 Penny is the manager of a nursery for pre-school children.

She knows that the ratio of the number of adults to the number of children must be 1 : 8

Penny has 56 children at the nursery.

(a) Work out the number of adults Penny needs for 56 children.

(2)



(b) Use a reverse calculation to show a check of your answer.

(1)

(Total for Question 8 is 3 marks)



- 9 Scott is a journalist.  
He is writing an article about fish and chip shops in his town.

The table shows the prices of a standard portion of fish and chips in 5 local shops.

shop	A	B	C	D	E
cost (£)	7.60	6.25	5.85	6.65	8.00

Scott thinks the mean price of a standard portion of fish and chips in these 5 shops is £6.85

- (a) Is Scott correct?  
Show why you think this.

(3)



- (b) Use estimation to show a check of your answer.

(1)

(Total for Question 9 is 4 marks)

DO NOT WRITE IN THIS AREA

DO NOT WRITE IN THIS AREA

DO NOT WRITE IN THIS AREA

DO NOT WRITE IN THIS AREA

DO NOT WRITE IN THIS AREA

DO NOT WRITE IN THIS AREA



DO NOT WRITE IN THIS AREA

DO NOT WRITE IN THIS AREA

DO NOT WRITE IN THIS AREA

DO NOT WRITE IN THIS AREA

DO NOT WRITE IN THIS AREA

DO NOT WRITE IN THIS AREA

**10** Matteo works for the local council.  
The council has 1260 grit bins.

The council will increase the number of grit bins by 5%  
Matteo thinks there will be more than 1300 grit bins after the increase.

Is Matteo correct?  
You **must** show your working.

(3)

(Total for Question 10 is 3 marks)



- 11 Lanza is a gardener.  
She has this plan of a garden.

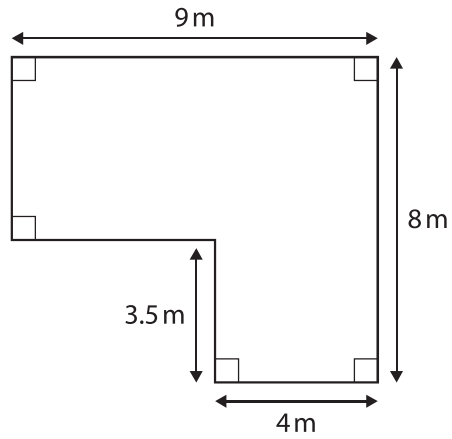

Lanza needs to put grass turf to cover this garden.  
She charges £16 a square metre to put grass turf in a garden.

Lanza thinks she will need to charge more than £800 to put grass turf in this garden.

Is she correct?  
Show why you think this.

(5)

DO NOT WRITE IN THIS AREA

DO NOT WRITE IN THIS AREA

DO NOT WRITE IN THIS AREA

DO NOT WRITE IN THIS AREA

DO NOT WRITE IN THIS AREA

DO NOT WRITE IN THIS AREA



DO NOT WRITE IN THIS AREA

DO NOT WRITE IN THIS AREA

DO NOT WRITE IN THIS AREA

DO NOT WRITE IN THIS AREA

DO NOT WRITE IN THIS AREA

DO NOT WRITE IN THIS AREA

(Total for Question 11 is 5 marks)

**TOTAL FOR SECTION B IS 42 MARKS**  
**TOTAL FOR PAPER IS 56 MARKS**



DO NOT WRITE IN THIS AREA

DO NOT WRITE IN THIS AREA

DO NOT WRITE IN THIS AREA

BLANK PAGE

